

## Enhanced EE2003-based Short Wave Receiver

Jurjen Kranenburg, January 2003 (revised December 2003)

<http://www.kranenburg.org/ee>

*{Please contact me via my website if you find this page interesting and have built the receiver yourself: I am interested in your experiences. I gratefully thank Tor Gjerde for his support in publishing this document on the Internet}*

### Summary

This article describes a small enhancement I made to the EE2003 Short Wave (SW) receiver that turns it into a simple but sensitive and user-friendly world receiver. This so-called *regenerative* receiver can be used for both general short wave listening on the 49m, 41m and 31m AM-type broadcast bands, as well as for SSB (Single Side-Band) reception of amateur and marine/aircraft stations. The major change is the addition of regeneration control which allows the receiver to be tuned for optimal sensitivity/selectivity for the complete frequency range (5.8 – 10MHz) as well as the addition (for SSB reception) or removal (for broadcast reception) of the regeneration “beat-note” frequency. With this design, I have received - from my home location in the Netherlands - several distant broadcast stations like All India Radio, Radio Yerevan (Armenia), Radio Bangkok, Radio Tokyo, Australia etc. and various European SSB amateur stations without using an external antenna.

### Background

About two years ago I re-discovered my Philips kits (the set now consists of the complete EE2000 and EE2001 series) and revived the electronics hobby after a period of almost twenty years. Since I am particularly interested in receiver designs, I built most of them again, and so I came across the EE2003 SW receiver (nr. 5.03). The manual mentions that it is a so-called superregenerative or “superreg” design (although seemingly a very simple circuit it is actually quite difficult to understand, see Ref.1 for a thorough explanation). A key feature of superregs is the very high amplification factor (over 100,000), which causes the typical noise or “hiss” that can be heard when the receiver is not tuned in to a particular station, the noise being caused by thermal fluctuations generated in the receiver front-end components.

Although the original receiver did work it had two peculiarities: a) the receiver was “deaf” at higher frequencies while oscillations associated with radio stations abounded in the lower frequency region, b) the receiver did not produce the “hiss” that is typical of superreg designs (for example, the FM receivers of EE2010/EE2013 clearly do). The oscillations that can be heard while tuning in to stations are typical of *regenerative* receivers, where part of the amplified RF signal is fed back into the RF stage, which leads to the oscillations mentioned before if the amount of feedback is relatively large.

To investigate the behaviour of the receiver I decided to replace the fixed 22K resistor (R4) with a 47K trimming potentiometer in series with a protective 4,7K resistor, expecting that this would allow to a superreg type of behaviour. Instead, it appeared that this new configuration controlled the amount of feedback (by controlling the T1 emitter-collector voltage difference), and allowed for a setting just below the onset of oscillation. In that case the regenerative receiver has maximum sensitivity and selectivity for AM type (broadcast) stations. When in the oscillating mode (i.e. strong feedback), the receiver itself provides for the carrier signal that is needed to demodulate stations of the so-called SSB (Single Side-Band) type, which encompasses most of the amateur, marine and aircraft stations. Since the amount of feedback (and thus the boundary between the oscillating and non-oscillating regimes) depends on the frequency, both the tuning capacitor and the regeneration trimmer have to be adjusted when one travels the frequency band. After some experimentation and the addition of a few components, I derived appropriate values for some components that allow for listening to both AM and SSB signals over the complete frequency range of the receiver. Note that with this regenerative receiver design the Philips EE2000 series now covers *all* receiver concepts: diode, reflex, regenerative, superregenerative, and superheterodyne.

In the section below this design is presented, with clear indications of the differences between the original design. Subsequently, I describe some tuning practices as well as the kinds of stations that can be received within the frequency range. I conclude with some examples and design issues which became apparent in my design.

## Design

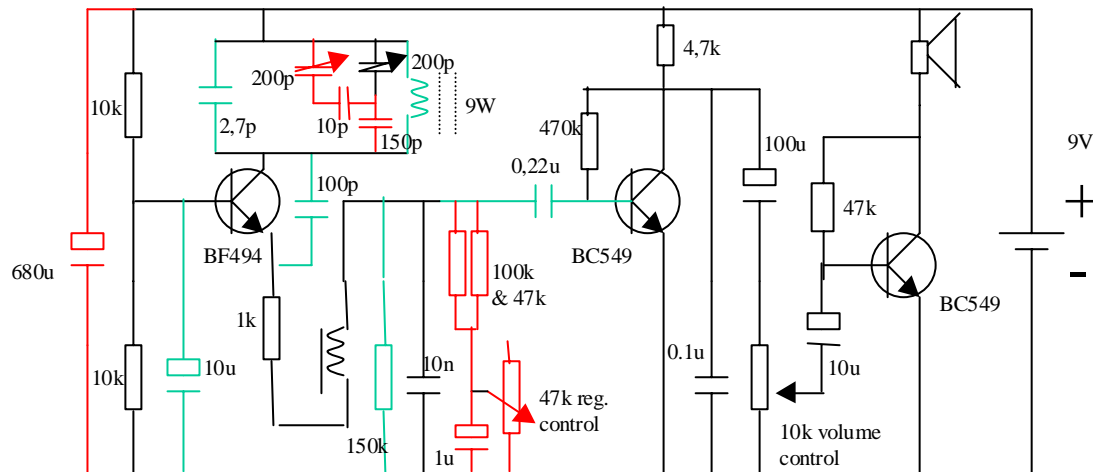

The figure above shows a schematic diagram of the receiver. A red color denotes a newly added component, a green one indicates a change of value for an existing component. The latter has been done to allow the three shortwave broadcast bands to be in the tuning range without the need for bandswitching. The extra components can be easily added to the original construction diagram in the EE2003 manual.

The following changes and additions have been made (with refs to the original component numbers):

1. The main coil: Used to be 8 windings in the center of the ferrite rod; now becomes 9 turns near the edge (see the photographs at the end of this document). This change was made to allow for the desired tuning range.
2. C1 (at the base of T1): used to be 0.1uF (Polyester), now changed to at least 10uF to prevent slow oscillation of the system that prevents proper functioning.
3. C2: Used to be 47 pF, now increased to 100pF, to allow for sufficient regeneration at low frequencies (T1 is used as a common-base amplifier with fixed regeneration feedback through C2 !).
4. C4: Used to be 10 pF, now lowered to 2.7 pF or even smaller to allow reception of the full 31m band. This value is not standard in the EE-series, so you may well remove C4 if you don't have such a small valued capacitor.
5. R4: Used to be 22K, now becomes 150K. This resistor influences the "spread" in regeneration control.
6. C6: Used to be 4,7uF, now becomes 0.22uF (Polyester).
7. NEW: I added a 100uF (or even larger) capacitor for undisturbed reception of stronger stations. Without this capacitor the receiver tends to "motorboat" even at average volume levels.
8. NEW: In series with the main tuning capacitor I added a 150p capacitor (or using 100pF + 47pF in parallel) for a proper tuning range (without this change the regeneration level remains to low at low frequencies).
9. NEW: In parallel to the main tuning capacitor I added a second, fine-tuning capacitor (I used the EE2005 double variable capacitor in series with a small 10pF capacitor). This greatly increases tuning satisfaction and therefore is strongly recommended! In case you don't have a second variable capacitor but do have the BB110 varactor (from EE2010/2013), you may use the latter in series with a 10p of 22p capacitor as well.
10. NEW: A 47K regeneration control potmeter has been added for regeneration control. Since the regeneration control should be quite accurate, use a high-quality potmeter (I bought a new one and mounted it into the console). I added a 1uF capacitor also to have real smooth control; its value is not critical, but should probably not be larger than 4,7uF and at least amount to 0.1uF.
11. NEW: A parallel combination of a 100K and 47K resistor in series with the regeneration potmeter provided for a proper regeneration range.

Note that the regeneration control part is outside the RF part of the circuit (as opposed to most other regenerative designs) because the RF choke coil separates them. Practically, this implies that long leads may be used to connect to the regen potmeter, and allows it to be part of the console (in my case, but you may also use the 47K trimming pots of for example EE2004/2010/2014 etc.).

Since the regeneration level depends on the T1 collector-emitter voltage difference, the regeneration level depends on the battery voltage as well. When the batteries get somewhat exhausted you will arrive at a point where you have to replace the 100K-47K combination with a 33K or even 22K resistor.

An alternative design (appropriate for owners of one the EE2001 series kits) uses a more modern LF part which consists of two operational amplifiers; it is almost identical to the LF part of the EE2010/2013 FM receiver. The circuit diagram is printed below. This is the version I implemented, several photographs of the construction are given at the end of this document.

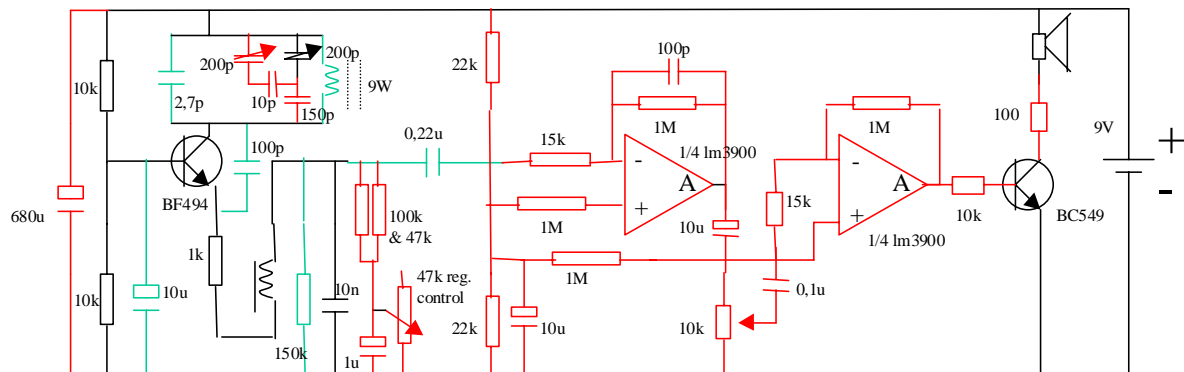

Based on this design I built the receiver several times; in total it was "alive" for more than a year because it performed so well!

### Construction Diagrams

The construction diagrams for both receiver versions are given below and were generated by Tor Gjerde. On my website links to PDF versions of the constructions are given, which can be printed and used directly on the breadboard (it should be printed in exactly the same size, no scaling to fit the paper).

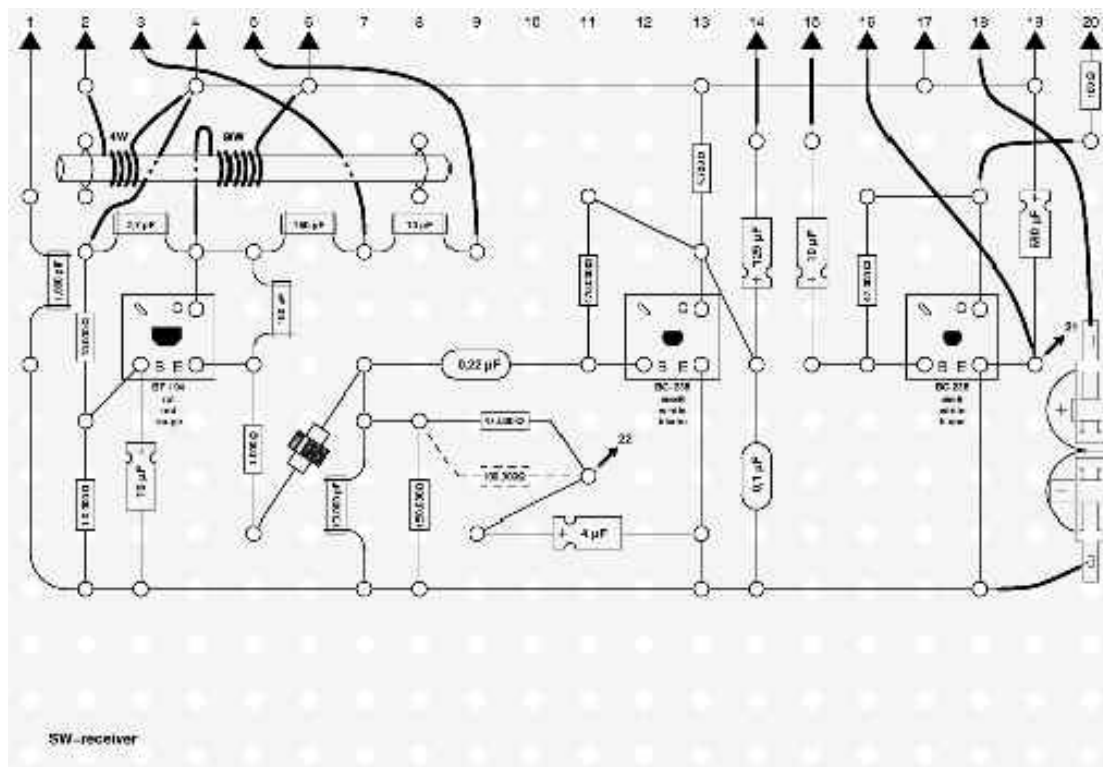

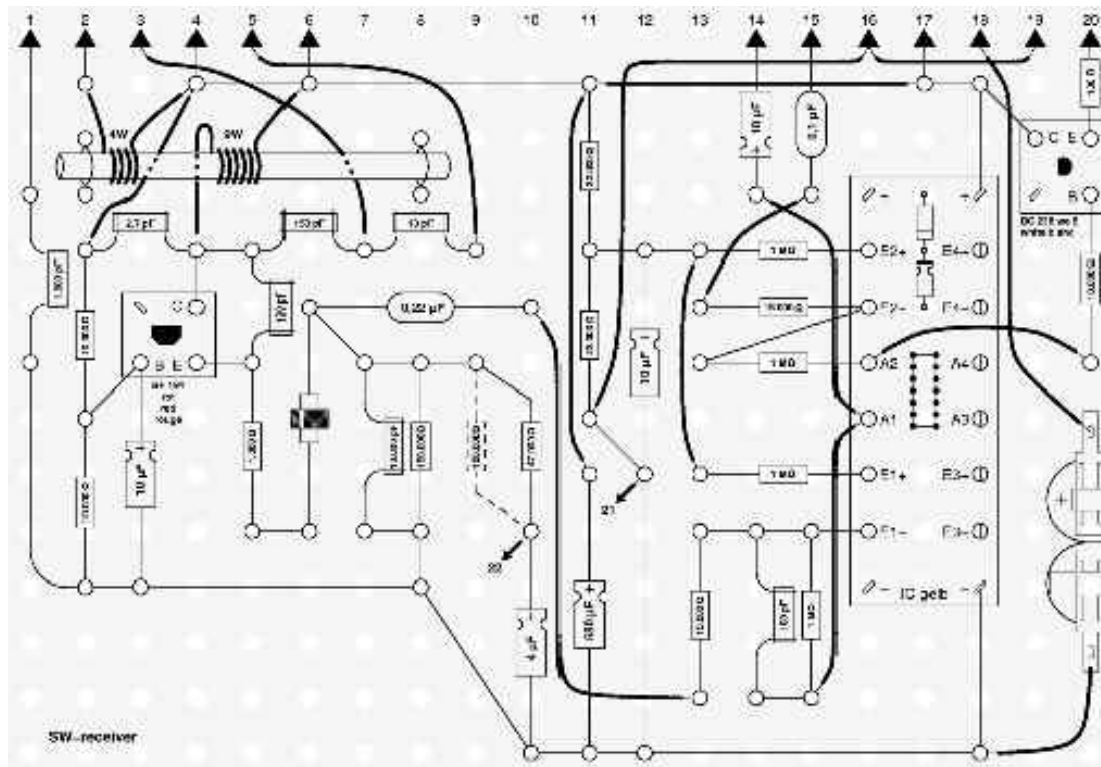

## Practical Use

### Tuning frequency range overview

The tuning range of the regenerative receiver covers three important short wave broadcast bands (49m, 41m and 31m) as well as some SSB amateur (40m) and maritime/aircraft (35m, 45m) bands. For the broadcast bands the best reception conditions are met at a few hours before sunset till a few hours after sunset. However, during spring and summer excellent conditions may sometimes persist until or after midnight for the higher frequencies. During daytime generally only relatively local broadcast stations can be received, as the reflective atmospheric layers are destroyed under influence of the sun. SSB reception is best during daytime, because then these weak stations are not overruled by strong international broadcast stations (of which Russian and Middle-East stations are notorious examples).

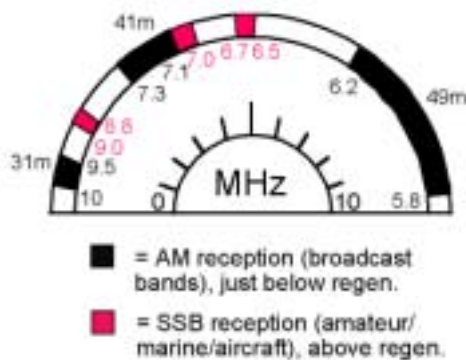

An overview of the receiver frequency range is presented in the figure at the left, which depicts the main tuning capacitor dial. At the right side the 49m broadcast band can be found, which contains many strong European stations, as well as stations from the Americas. In the 41m band I located many strong stations which are apparently from the Middle East, in addition to several other interesting stations (like All India Radio, Radio Albania, several Russian stations, some weak unidentified Chinese (?) stations). Late in the evening some Middle-East stations may become very strong and tend to “overrule” the others. The 31m band is very interesting because it contains various distant stations (like Bangkok, Vietnam, Radio Cairo) as well as more near stations, (Yerevan (Armenia), Turkey) but these are also quite difficult to pin down without fine-tuning.

The red areas in the dial indicate regions which contain interesting SSB stations, mainly amateurs, although they possibly also contain aircraft and/or maritime stations (35m band). Particularly the 7.0-7.1 MHz interval is filled with several amateur stations from various European countries (Based on my location in the south of the Netherland the German amateurs are particularly strong, but I have also received Dutch, Belgian, French,

English and even Italian stations). A fine tuning capacitor is definitely needed to tune to the proper sideband (generally but not exclusively the upper sideband). The SSB signals are very weak, you need maximum volume and your ear in close proximity to the speaker to understand their messages. Best receiving conditions are during daylight; in the late evening and during the night strong (Middle East) broadcast stations overrule the weak SSB signals. Nevertheless, I have received several of them clearly despite their low audio volume (some of them are involved in quite uninteresting discussions about their station equipment, probably in the same way that some men talk about their fancy cars ...).

The other two SSB bands are very weak regarding my location (especially the 35m band at 8.5-9 Mhz), I generally had great difficulties with listening to stations. This may however turn out differently on your location.

I want to note that I never have used an external antenna since it did not significantly increase the capabilities of the receiver (in many cases an antenna caused overloading of the receiver by strong broadcast stations and added a lot of background noise). Maybe an antenna helps for SSB stations, but I have no experience in that matter.

## Tuning guidelines

If you operate the receiver for the first time, you should check whether you can tune the regeneration level to both AM and SSB reception for the complete frequency range. To do so, take the following steps:

- Turn the main tuning dial (variable capacitor) to the right, tuning in a station on the 49m band, which corresponds to a low frequency. Set the regeneration level at maximum by setting the regeneration potentiometer at the lowest level ( $R=0$ ). You should hear a loud tone (the beat note) in addition to the station itself. Now decrease the regeneration level ( $R$  becomes larger) until you note that the tone disappears. This should happen at a relatively low regeneration level ( $R$  relatively large). In case it happens at a high regeneration level or the beat note cannot be heard at all, decrease the 100K resistor near the trimming potmeter. If the beat note remains at all regeneration levels, the regeneration must be decreased by increasing the 100K or the 47K resistor in value.
- Set the regeneration level to a maximum ( $R=0$ ) again. Now turn the tuning dial from the right to the left (highest frequency). As you turn you should hear the oscillations that correspond to the received radio stations. In particular you should note that most of the stations are clustered in three groups, each of the groups corresponding with one of the three broadcast bands. When you arrive at 10MHz, you should still hear the beat notes associated with each station. If the beat note cannot be heard anymore, the regeneration level is still to low even at  $R=0$ , and you must decrease the value of the 100K resistor.
- At 10 MHz reduce the regeneration level by increasing the potentiometer resistance. At some point you should note a sudden decrease in noise level (in case you are not tuned to a station) or the regeneration tone suddenly disappears (in case you are tuned to a station).

Tuning on a regenerative receiver is a two-handed affair; some experimentation will provide for the best strategy. An appropriate approach is the following:

- Always search from low to high frequency.
- Set the regeneration level at such a level that regeneration occurs, i.e. the beat note can be heard. This will allow you to identify even very weak stations, including SSB and various morsecode stations, and it helps to identify the start of the broadcast bands
- If you have arrived roughly at the appropriate location. reduce the regeneration level to just below the onset of oscillation. With this setting the receiver has maximum sensitivity and selectivity for broadcast (AM) reception. Use fine tuning to tune in to the station of interest. If you change the frequency, also change the regeneration level in order to retain maximum sensitivity.
- In case you want to receive SSB stations, keep the regeneration level high.

The best place to operate this receiver is at the first or second floor of your house.

## Station info

Although I will provide for a simple tuning guide in a later update of this document, Ref. 2 provides very useful information on broadcast schemes in the English language (sorted in various ways, for example: time, frequency, country etc.etc.) and various issues and numerous links on shortwave listening. Highly recommended!

## **An example: my construction**

I took some photographs of my receiver to give an impression of the measures I took to secure stable operation.



The picture at the left shows the complete construction. Note that I actually built the design with the opamp amplifier, although the original transistor design should work as well. The two large knobs are for the main frequency tuning and for fine tuning, while the silver knobs are for regeneration control (using a 47K linear potentiometer) and volume control (the original 10K log potentiometer). Note that especially the regeneration potentiometer should be of high quality, since the regeneration level must be adjusted quite accurately for optimal receiver sensitivity and selectivity. To this end I bought a new one, but you may also try the 47K trimming pot of EE2004/2010/2013 etc.



This picture shows the RF part of the receiver. The coil consists of 9 turns which need to be very carefully and closely wound. The red coil is for the antenna and should be immediately adjacent to the main coil. Both coils should be near the end of the ferrite coil. In practice, I never used an antenna. For optimal contact the transistor is mounted *upon* the components (as is suggested by the Philips manual for the EE2010/13 FM receiver). This is good practice for all designs.

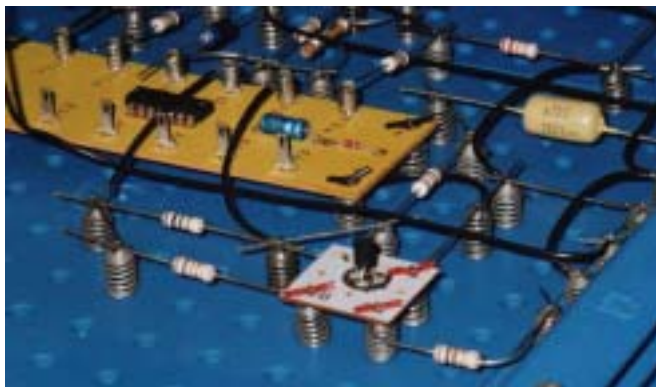

The LF part of the receiver is shown here. It appeared to be good practice to always mount the transistors and ICs upon the components and wires, since this provides for much better contact. Isolated wire is used to fix them. In this way you can even walk around with your receiver without hearing any disturbances.

## **References**

1. E. Insam; Designing Super-Regens, in: Electronics World, April 2002
2. Prime Time Shortwave Guide ([www.primetimeshortwave.com](http://www.primetimeshortwave.com))